

TRAXXIS 55
55 LBS THRUST
12 VOLT 50 AMPS
36" OR 42" SHAFT

for use with "0" serial numbers
2-year warranty

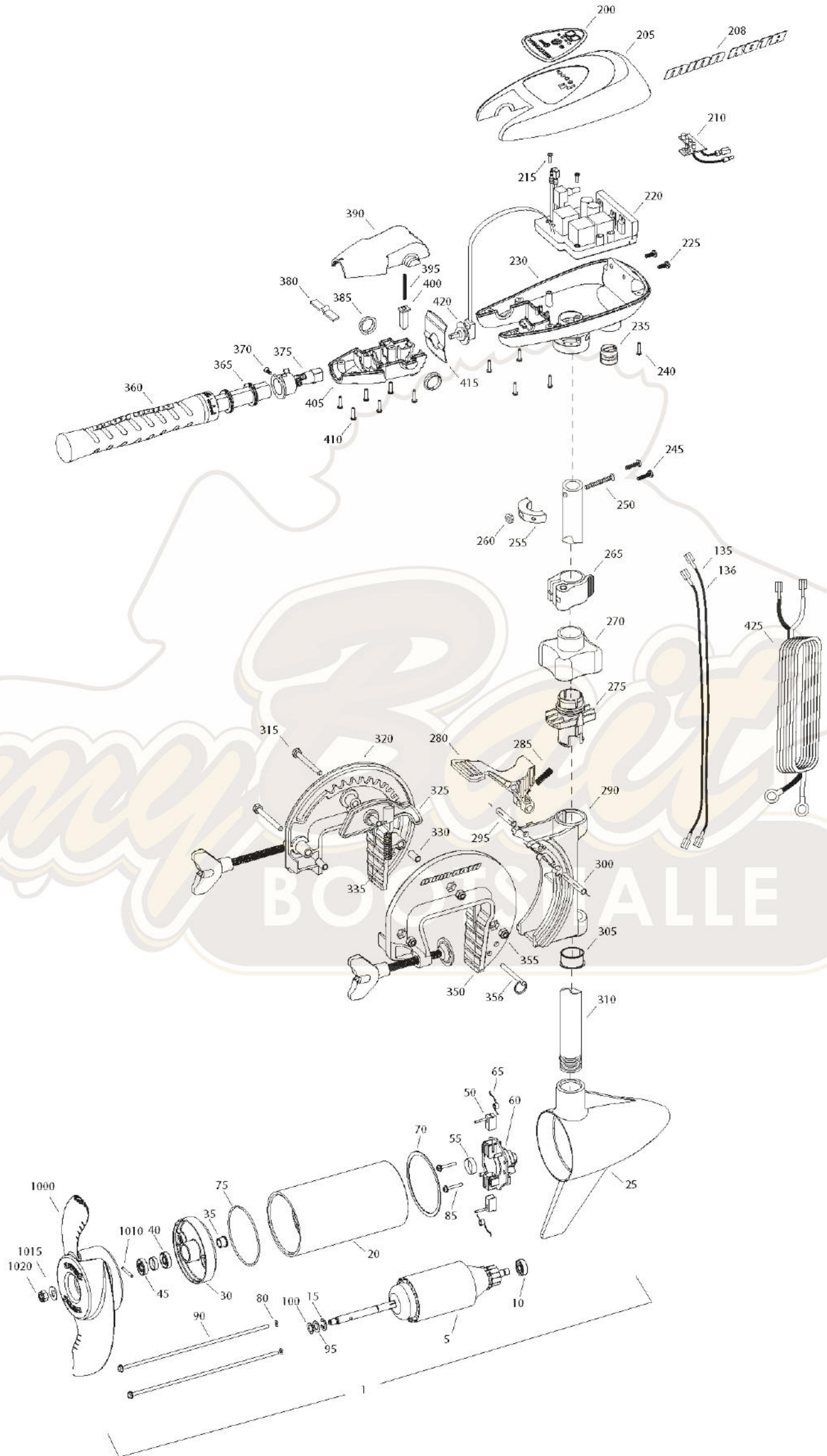

Item	P/N	Description	Qty	Item	P/N	Description	Qty
1	2097074	12V Motor 42" FW	1	■	2991795	Bracket assy, Composite [270-356]	1
5	2-100-121	Armature assembly	1	270	2060100	Knob, steering tension, soft	1
10	140-010	Bearing	1	275	2068400	Collet	1
15	788-015	Retaining ring	1	280	2064200	Lock arm	1
20	2-200-101	Center housing assembly	1	285	2062701	Spring, lock arm	1
25	421-065	Brush end housing assembly	1	290	2061821	Hinge	1
30	2-400-101	Plain end housing assembly	1	295	2062602	Pin, lock, Zinc	1
35	144-049	Flange bearing	1	300	2062602	Pin, lock, Zinc	1
40	880-003	Seal	1	305	2037301	Bushing, hinge	1
45	880-006	Seal with shield	1	310	2032052	Tube 36"	1
50	188-036	Brush	2		2032053	Tube 42"	1
55	725-050	Paper tube	1				
60	738-036	Brush plate assembly	1	315	2063500	Bolt 1/4-20 x 2 3/8", Zinc	3
65	975-040	Brush spring	2	320	2771950	Bracket, right, FW	1
70	337-036	Gasket	1	325	2067905	Cam deactivator	1
75	701-081	O-ring, motor	1	330	2067306	Bushing, dowel 1/4 x 1/2	3
80	701-008	O-ring, thru-bolt	2	335	2062702	Spring, cam deactivator	1
85	830-007	Screw, 8-32	2	■	2881380	Clamp screw kit	2 per kit
90	830-042	Thru-bolt	2	350	2771955	Bracket, left, FW	1
95	990-067	Washer, steel	2	355	2263104	Nut, 1/4-20, nylock, Zinc	3
100	990-070	Washer, nylatron	2	356	2062604	Pin, stop	1
135	640-004	Leadwire, black	1				
136	640-105	Leadwire, red	1	■	2990957	Handle assy, VARS [360-410]	1
■	2888460	Seal and O-ring Kit		360	2990456	Grip/handle assy, VARS [360-375]	1
				365	2060015	Bearing, handle	2
200	2065697	Decal, c-box cover	1	370	2063405	Screw, #6 PFH SS	1
205	2060295	C-box cover	1	375	2884092	Yoke / spider assy, VARS	1
208	2325665	Decal - MinnKota	2	380	2302742	Spring, detent, off	1
210	2074070	Battery meter, 12v FW	1	385	2060005	Bearing, handle pivot	2
215	3043427	Screw, #8 x 7/8 SS	2	390	2060900	Handle pivot, top	1
220	2184016	Control board, 12v	1	395	2302745	Spring, release button	1
■	2888411	Potentiometer Replacement Kit		400	2063700	Button, release	1
225	2303434	Screw, #8-30 x 5/8 SS	2	405	2060905	Handle pivot, bottom	1
230	2062501	Control box, VARS, FW	1	410	2303412	Screw, #6 x 5/8 SS	6
235	2062905	Strain relief	1				
240	2303412	Screw, #6 x 5/8 SS	6	415	2062715	Spring, handle pivot	1
245	2263434	Screw, #8 x 1 SS	2	420	2061700	Washer, pot holder	1
250	2383407	Screw, #10-24 x 2 SS	1	425	2992523	Leadwire assy, includes [235]	1
255	2061515	Collar, c-box	1				
260	2383124	Nut, 10-24, nylock, SS	1	■	1378170	Propeller kit	
265	2991521	Cam lock/depth collar assy	1	■	2994875	Propeller bag assy	
				1000	2091170	Propeller	1
				1010	2092600	Drive pin, small	1
				1015	2151726	Washer, prop, small	1
				1020	2053101	Nut, nylock, prop, small	1

BOATSHALLE

12-24-36 VOLT VARIABLE SPEED MODELS

THIS IS A UNIVERSAL MULTI-VOLTAGE DIAGRAM. DOUBLE CHECK YOUR MOTORS VOLTAGE FOR PROPER CONNECTIONS

Traxxis 55 is 12-volt only!

