

TERROVA 80
80 LBS THRUST
24 VOLT 56 AMPS
45", 54" OR 60" SHAFT

for use with "K" serial numbers
2-year warranty from the date of purchase

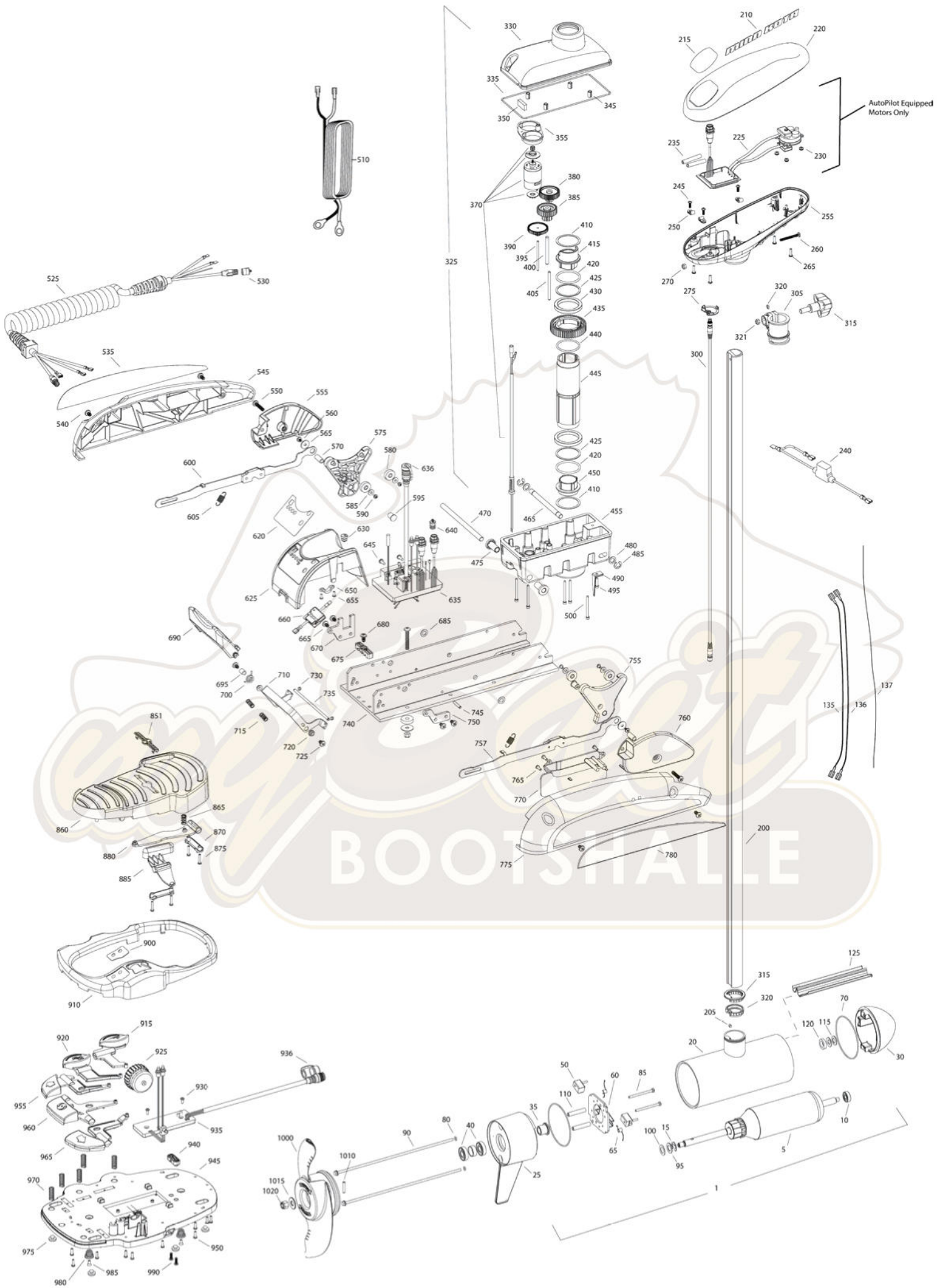

| Item | P/N | Description | Qty | Item | P/N | Description | Qty | Item | P/N | Description | Qty | Item | P/N | Description | Qty |
|------|-----------|-------------------------------------|-----|------|---------|-----------------------------------|-----|------|---------|---------------------------------|-----|------|---------|----------------------------|-----|
| 1 | 2777002 | 24V Motor 60" FW | 1 | 300 | 2211415 | Universal sonar 2 extension cable | 1 | 595 | 2324705 | Insert, ramp | 2 | 936 | 2320207 | Dust cap | 1 |
| | 2777001 | 24V Motor 54" FW | 1 | 305 | 2771500 | Depth collar assembly | 1 | 600 | 2994204 | Arm, release, left | 1 | 940 | 2322900 | Strain relief, foot pedal | 1 |
| | 2777000 | 24V Motor 45" FW | 1 | 315 | 2260906 | Knob (included in #305) | 1 | 605 | 2322710 | Spring, extension | 2 | 945 | 2324500 | Base plate, foot pedal | 1 |
| | 2777004 | 24V Motor US2 60" | 1 | 320 | 2321706 | Washer (included in #305) | 1 | █ | 2770250 | Cover, speed control with decal | 1 | 950 | 2301310 | Screw, #8 x .5 | 10 |
| | 2777003 | 24V Motor US2 54" | 1 | 321 | 2323102 | Nut (included in #305) | 1 | 620 | 2325650 | Decal, speed control | 1 | 955 | 2323700 | Button, steer, left | 1 |
| | 2777005 | 24V Motor US2 45" | 1 | 325 | 2997020 | Steering housing | 1 | 625 | 2320210 | Cover, speed control | 1 | 960 | 2323705 | Button, momentary | 1 |
| 5 | 2-100-214 | Armature assembly | 1 | 330 | 2326501 | Steering housing top | 1 | 630 | 2322901 | Strain relief | 1 | 965 | 2323701 | Button, steer, right | 1 |
| 10 | 140-010 | Bearing | 1 | 335 | 2324604 | O-ring, case seal | 1 | 635 | 2324012 | Control board, 24-36v | 1 | 970 | 2322704 | Spring, foot pedal | 5 |
| 15 | 788-040 | Retaining ring | 1 | 345 | 2305605 | Roll pin 5/16 | 4 | █ | 2884050 | Switch-reed repair kit | 1 | 975 | 2994859 | Bumper, bag assy | 1 |
| 20 | | Included in #200 assembly | | 350 | 2308601 | Breather, filter | 1 | 636 | 2320208 | Dust plug | 1 | 980 | 2322706 | Spring, barrel | 2 |
| 25 | 2-300-170 | Brush end housing assembly | 1 | 355 | 2328610 | Cradle, motor | 1 | 640 | 2320203 | Cap, dust, control board | 1 | 985 | 2323420 | Screw, 8-18 x .375 | 2 |
| 30 | 421-276 | Plain end housing assembly STD | 1 | 370 | 2777020 | Motor, steering assembly | 1 | 645 | 2323406 | Screw, 10-24 x | 2 | 990 | 2372100 | Screw, 8-18 x .625 | 2 |
| | 9421-286 | Plain end housing US2 60" | 1 | 380 | 2302255 | Gear, cluster 3rd stage | 1 | 650 | 2321315 | Holder, connector | 1 | | | | |
| | 9421-285 | Plain end housing US2 54" | 1 | 385 | 2302250 | Gear, cluster 2nd stage | 1 | 655 | 2332103 | Screw, 6-20 x .375 | 2 | █ | 1378132 | Propeller kit WW2 | |
| | 9421-284 | Plain end housing US2 45" | 1 | 390 | 2302245 | Gear, cluster 1st stage | 1 | 660 | 2074071 | Battery meter, 24v | 1 | █ | 2994876 | Propeller bag assy | |
| 35 | 144-017 | Flange bearing | 1 | 395 | 2302610 | Shaft, gear 1st stage | 1 | 665 | 2323402 | Screw, 1/4-20 x .375 | 4 | 1000 | 2331160 | Propeller WW2 | 1 |
| 40 | 880-025 | Seal | 2 | 400 | 2302620 | Shaft, gear 3rd stage | 1 | 670 | 2321940 | Bracket, strain relief | 1 | 1010 | 2262658 | Drive pin, large | 1 |
| 50 | 188-094 | Brush | 2 | 405 | 2302615 | Shaft, gear 2nd stage | 1 | 675 | 2321310 | Strain relief, wire | 1 | 1015 | 2091701 | Washer, prop, large | 1 |
| 60 | 2-600-199 | Brush plate assembly | 1 | 410 | 2321704 | Washer, thrust | 2 | 680 | 2323405 | Screw, 1/4-20 x .5 | 1 | 1020 | 2093101 | Nut, nylock, prop, large | 1 |
| 65 | 975-041 | Brush spring | 2 | 415 | 2321515 | Liner, output tube | 1 | 685 | 2013100 | Speed nut, .375 | 2 | | | | |
| 70 | 701-043 | O-ring, motor | 2 | 420 | 2324608 | O-ring, 224 | 2 | 690 | 2320215 | Handle, release cover | 1 | █ | 2994864 | Mounting hardware bag assy | |
| 80 | 701-009 | O-ring, thru-bolt | 2 | 425 | 2321720 | Shim, O-ring | 2 | 695 | 2301700 | Bushing, | 1 | | | | |
| 85 | 830-027 | Screw, 10-32 x 2 | 2 | 430 | 2327308 | Bearing, ball sealed | 2 | 700 | 2322701 | Spring, release handle | 1 | █ | 2889460 | Seal & Oring Kit | |
| 90 | 830-094 | Thru-bolt | 2 | 435 | 2322200 | Gear, output | 1 | 710 | 2320400 | Handle, release FW | 1 | | | | |
| | 830-095 | Thru-bolt, Sonar only | 2 | 440 | 2324601 | O-ring, output gear | 1 | 715 | 2322712 | Spring, release handle | 2 | | | | |
| 95 | 990-051 | Washer, steel | 2 | 445 | 2322030 | Tube, output machined | 1 | 720 | 2322604 | Bushing, handle | 2 | | | | |
| 100 | 990-052 | Washer, nyatron | 2 | 450 | 2321510 | Collar, drive, bottom | 1 | 725 | 2332104 | Screw, 1/4-20 x .625 | 2 | | | | |
| 110 | 973-025 | Spacer, brush plate | 2 | 455 | 2326506 | Steering housing, Bottom | 1 | 730 | 2323000 | E-clip, 3/16, SS | 2 | | | | |
| 115 | 992-010 | Washer, Belleville | 2 | 465 | 2322600 | Pin, latch, zp | 1 | 735 | 2322606 | Pin, follower, handle | 1 | | | | |
| 120 | 990-045 | Spacer, thrust | 1 | 470 | 2322602 | Pin, pivot, zp | 1 | 740 | 2321901 | Base extrusion, machined | 1 | | | | |
| 125 | 582-013 | Clip, retaining, short | 1 | 475 | 2327310 | Bushing, pivot pin | 2 | 745 | 2322912 | Spring pin, | 2 | | | | |
| 135 | 640-025 | Leadwire, black | 1 | 480 | 2321702 | Washer, flat .375 | 2 | 750 | 2321950 | Bracket, sideplate | 1 | | | | |
| 136 | 640-133 | Leadwire, red | 1 | 485 | 2263011 | E-ring .375 | 2 | 755 | 2323900 | Ramp, 4" right | 1 | | | | |
| 137 | 640-317 | Groundwire, brown, US2 only | 1 | 490 | 2322702 | Spring, latch pin | 2 | 757 | 2994202 | Arm, release, Right | 1 | | | | |
| 200 | 2777096 | Tube, composite 60" FW | 1 | 495 | 2323410 | Screw, 8-32 x .75 | 1 | 760 | 2321920 | Skid, right | 1 | | | | |
| 205 | | Included in #200 assembly | | 500 | 2323408 | Screw, 8-32 x 2 | 7 | 765 | 2301310 | Screw, 8-18 x .5 | 3 | | | | |
| 210 | 2325665 | Decal, cover | 2 | 510 | 2090651 | Leawire, 10 ga | 1 | 770 | 2320220 | Cover, access, FW | 1 | | | | |
| 215 | 2325674 | Decal, ctrl box 80 | 1 | 525 | 2991273 | Coil cord, 45" | 1 | 775 | 2321910 | Sideplate, right | 1 | | | | |
| | 2325675 | Decal, ctrl box 80 US2 | 1 | | 2991271 | Coil cord, 54" | 1 | 780 | 2325640 | Decal, sideplate, right | 1 | | | | |
| | 2325676 | Decal, ctrl box 80 Autopilot | 1 | | 2991274 | Coil cord, US2, 45" | 1 | 850 | 2994720 | Foot pedal | 1 | | | | |
| | 2325677 | Decal, ctrl box 80 Autopilot & US2 | 1 | | 2991272 | Coil cord, US2, 54" | 1 | 851 | 2326710 | Plug, foot pedal | 1 | | | | |
| 220 | 2320200 | Cover, ctrl box | 1 | 530 | 2320202 | Cap, dust, coil cord, non-AP only | 1 | 860 | 2324400 | Pedal, heel-toe | 1 | | | | |
| 225 | 2324030 | Ctrl board, compass, Autopilot only | 1 | 535 | 2325641 | Decal, sideplate, left | 1 | 865 | 2322714 | Spring, momentary | 1 | | | | |
| 230 | 2302960 | Grommet, compass, Autopilot only | 3 | 540 | 2323404 | Screw, 1/4-20 | 4 | 870 | 2321300 | Clamp | 2 | | | | |
| 235 | 2065400 | Wire insulator | 2 | 545 | 2321915 | Sideplate, left | 1 | 875 | 2223430 | Screw, 8 x .75 | 4 | | | | |
| 240 | 2218200 | Fuse holder, US2 only | 1 | 550 | 2323403 | Screw, 1/4-20 x .375 | 2 | 880 | 2328600 | Flex finger | 1 | | | | |
| 245 | 2372100 | Screw, 8-18 x .625 | 3 | 555 | 2321925 | Skid, left | 1 | 885 | 2323710 | Button, momentary, left | 1 | | | | |
| 250 | 2052510 | Cable clamp | 3 | 560 | 2323422 | Screw, 10-24 x .375 | 2 | 900 | 2325660 | Decal, foot pedal | 1 | | | | |
| 255 | 2322500 | Ctrl box | 1 | 565 | 2321700 | Washer, #10 SS | 2 | 910 | 2320205 | Cover, heel-toe | 1 | | | | |
| 260 | 2332102 | Screw, 10-24 | 1 | 570 | 2323500 | Bolt, shoulder | 2 | 915 | 2323725 | Button, AP | 1 | | | | |
| 265 | 2372100 | Screw, 8-18 x .625 | 4 | 575 | 2323905 | Ramp, 4" left | 1 | 920 | 2323715 | Button, Mom/Con | 1 | | | | |
| 270 | 2333101 | Nut, 10-24 | 1 | 580 | 2325115 | Pad, rubber rest | 4 | 925 | 2320100 | Knob, speed, foot pedal | 1 | | | | |
| 275 | 2224700 | Plug, ctrl box, US2 motors only | 1 | 585 | 2321706 | Washer, #8 | 4 | 930 | 2332103 | Screw, 6-20 x .375 | 2 | | | | |
| | 2224702 | Plug, ctrl box | 1 | 590 | 2323412 | Screw, 8-18 x .25 | 4 | 935 | 2324020 | Control board, foot pedal | 1 | | | | |

* This item is part of an assembly. This item cannot be sold separately due to machining and /or assembly that is required.

P/N 2324931

REV. W 31552 8-09

Terrova 80 is 24-volt only!

ACCESSORY PLUG
PRISE D'ACCESSOIRE

BATTERY GAUGE/
VOLTMÈTRE

COMPASS/
BOUSSOLE

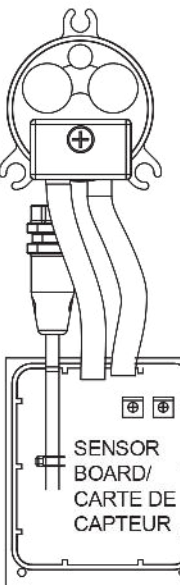

AUTOPILOT ON EQUIPPED MOTORS ONLY
PILOTE AUTOMATIQUE SEULEMENT SUR
MOTEURS ÉQUIPÉS



UNIVERSAL SONAR 2 EXTENSION WIRE *
SONAR UNIVERSEL 2 FIL D'EXTENSION *

BROWN *
MARRON *

FUSE *
FUSIBLE *

UNIVERSAL SONAR 2 WIRE *
SONAR UNIVERSEL 2 FIL *

RED/ROUGE M+

BLACK/NOIR M-

MOTOR/
MOTEUR

RED/ROUGE
BLACK/NOIR

BROWN/MARRON
BLACK/NOIR M-
RED/ROUGE M+

BLACK/NOIR B-

RED/ROUGE B+

CONTROL BOARD/
CARTE DE COMMANDE

12v

BATTERY 1
BATTERIE 1

24v

BATTERY 1
BATTERIE 1

BATTERY 2
BATTERIE 2

36v

BATTERY 1
BATTERIE 1

BATTERY 2
BATTERIE 2

BATTERY 3
BATTERIE 3

STEERING MOTOR/
MOTEUR DE DIRECTION

WHITE/BLANC

BLACK/NOIR

ACCESSORY PLUG
PRISE D'ACCESSOIRE

AUTOPILOT INDICATOR, RED
L'AUTOPILOT LUMIÈRE, ROUGE

SYSTEM READY INDICATOR, GREEN
SYSTÈME PRÊT LUMIÈRE, VERT

REED SWITCH
INTERRUPTEUR À ANCHE

FOOT PEDAL
CONTROL BOARD/
CARTE DE COMMANDE
DE LA PFD/DALE

SPEED ADJUSTMENT KNOB
MOLETTE DE REGLAGE DE
LA VITESSE

AUTO PILOT INDICATOR, RED
(EQUIPPED MOTORS ONLY)
L'AUTOPILOT LUMIÈRE, ROUGE
(MOTEURS ÉQUIPÉS SEULEMENT)

MOMENTARY / CONSTANT
INDICATOR, GREEN
MOMENTANÉ / CONTINU
LUMIÈRE, VERT

* US MOTORS ONLY

* MOTEURS US SEULEMENT