

55 TERROVA
55 LBS THRUST
12 VOLT 50 AMPS
48" OR 54" SHAFT

for use with "J" serial numbers
3-year warranty from the date of sale

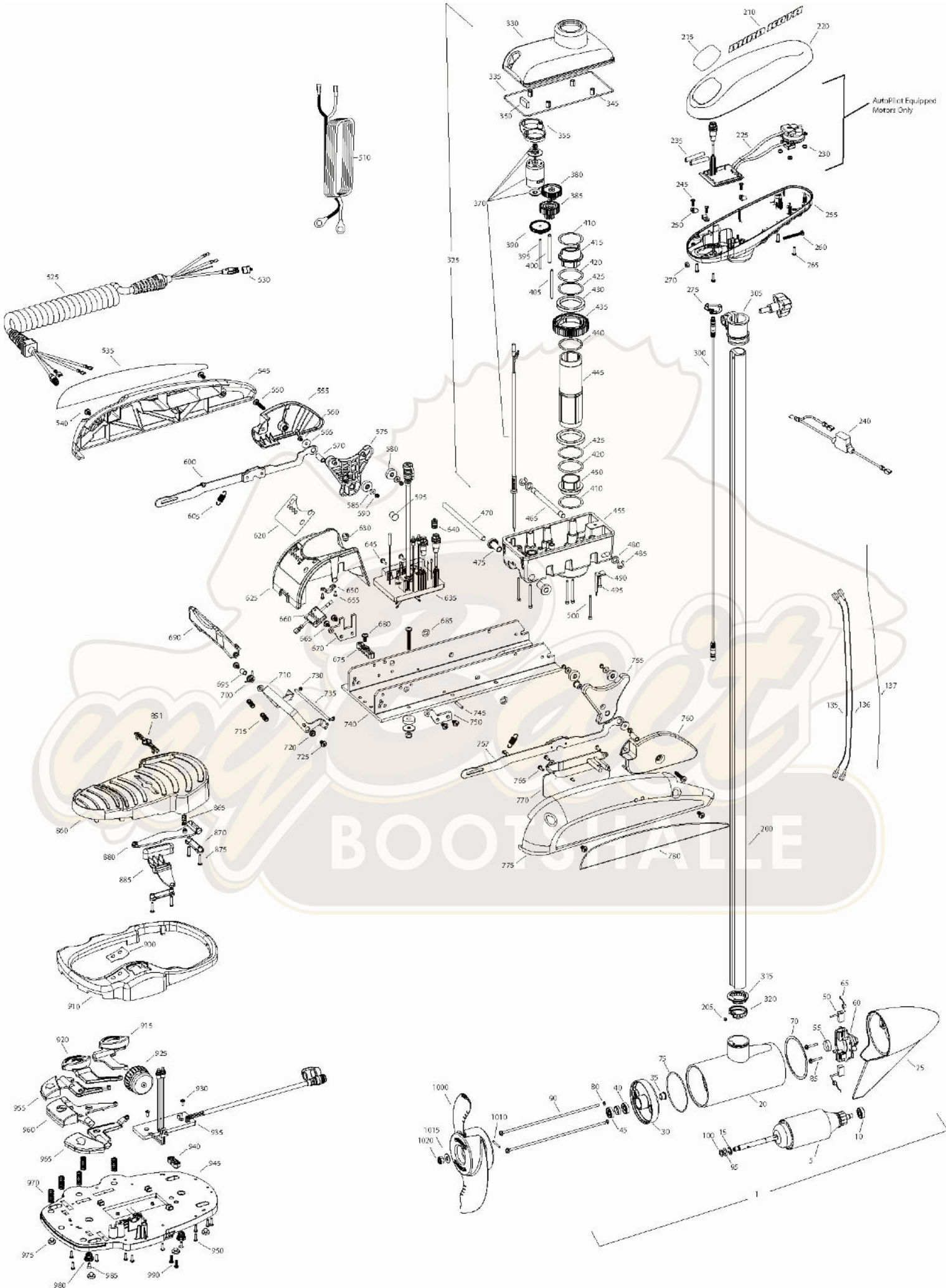

Item	P/N	Description	Qty	Item	P/N	Description	Qty	Item	P/N	Description	Qty	Item	P/N	Description	Qty
1	2779021	12V Motor 54" FW	1	330	2326501	Steering housing top	1	640	2320203	Cap, dust, control board	1	990	2372100	Screw, 8-18 x .625	2
	2779020	12V Motor 48" FW	1	335	2324604	O-ring, case seal	1	645	2323406	Screw, 10-24 x	2				
	2779023	12V Motor US2 54"	1	345	2305605	Roll pin 5/16	4	650	2321315	Holder, connector	1	■	1378131	Propeller kit WW2	
	2779022	12V Motor US2 48"	1	350	2308601	Breather, filter	1	655	2332103	Screw, 6-20 x .375	2	■	2994875	Propeller bag assy	
5	2-100-145	Armature assembly	1	355	2328610	Cradle, motor	1	660	2074070	Battery meter, 12v	1	1000	2091160	Propeller WW2	1
10	140-010	Bearing	1	370	2777055	Motor, steering, assy	1	665	2323402	Screw, 1/4-20 x .375	4	1010	2092600	Drive pin, small	1
15	788-015	Retaining ring	1	380	2302255	Gear, cluster 3rd stage	1	670	2321940	Bracket, strain relief	1	1015	2151726	Washer, prop, small	1
20		Included in #200 assembly		385	2302250	Gear, cluster 2nd stage	1	675	2321310	Strain relief, wire	1	1020	2053101	Nut, nylock, prop, small	1
25	421-050	Brush end housing assembly STD	1	390	2302245	Gear, cluster 1st stage	1	680	2323405	Screw, 1/4-20 x .5	1				
	9421-146	Plain end housing US2 54"	1	395	2302610	Shaft, gear 1st stage	1	685	2013100	Speed nut, .375	2	■	2994864	Mounting hardware bag assy	
	9421-145	Plain end housing US2 48"	1	400	2302620	Shaft, gear 3rd stage	1	690	2320215	Handle, release cover	1				
30	2-400-101	Plain end housing assembly	1	405	2302615	Shaft, gear 2nd stage	1	695	2301700	Bushing,	1				
35	144-049	Flange bearing	1	410	2321704	Washer, thrust	2	700	2322701	Spring, release handle	1				
40	880-003	Seal	1	415	2321515	Liner, output tube	1	710	2320400	Handle, release FW	1				
45	880-006	Seal with shield	1	420	2324608	O-ring, 224	2	715	2322712	Spring, release handle	2				
50	188-036	Brush	2	425	2321720	Shim, O-ring	2	720	2322604	Bushing, handle	2				
55	725-050	Paper tube	1	430	2327308	Bearing, ball sealed	2	725	2332104	Screw, 1/4-20 x .625	2				
60	2-600-216	Brush plate assembly	1	435	2322200	Gear, output	1	730	2323000	E-clip, 3/16, SS	2				
65	975-040	Brush spring	2	440	2324601	O-ring, output gear	1	735	2322606	Pin, follower, handle	1				
70	337-036	Gasket	1	445	2322030	Tube, output machined	1	740	2321901	Base extrusion, machined	1				
75	701-081	O-ring, motor	1	450	2321510	Collar, drive, bottom	1	745	2322912	Spring pin,	2				
80	701-008	O-ring, thru-bolt	2	455	2326506	Steering housing, Bottom	1	750	2321950	Bracket, sideplate	1				
85	830-007	Screw, 8-32	2	465	2322600	Pin, latch, zp	1	755	2323910	Ramp, 3 5/8" right	1				
90	830-008	Thru-bolt	2	470	2322602	Pin, pivot, zp	1	757	2994204	Arm, release, Right	1				
95	990-067	Washer, steel	2	475	2327310	Bushing, pivot pin	2	760	2321920	Skid, right	1				
100	990-070	Washer, nylon	2	480	2321702	Washer, flat .375	2	765	2301310	Screw, 8-18 x .5	3				
135	640-031	Leadwire, black	1	485	2263011	E-ring .375	2	770	2320220	Cover, access, FW	1				
136	640-135	Leadwire, red	1	490	2322702	Spring, latch pin	2	775	2321910	Sideplate, right	1				
137	640-316	Groundwire, brown, US2 only	1	495	2323410	Screw, 8-32 x .75	1	780	2325640	Decal, sideplate, right	1				
200	2779105	Tube, composite 54" FW	1	500	2323408	Screw, 8-32 x 2	7	850	2994720	Foot pedal	1				
205		Included in #200 assembly		510	2090651	Leawire, 10 ga	1	851	2326710	Plug, foot pedal	1				
210	2325665	Decal, cover	2	525	2991273/2991271	Coil cord 45"/54"	1	860	2324400	Pedal, heel-toe	1				
215	2325670	Decal, ctrl box 55	1		2991274/2991272	Coil cord, US2 48"/54"	1	865	2322714	Spring, momentary	1				
	2325671	Decal, ctrl box 55 US2	1	530	2320202	Cap, dust, coil cord, non-AP only	1	870	2321300	Clamp	2				
	2325672	Decal, ctrl box 55 Autopilot	1	535	2325641	Decal, sideplate, left	1	875	2223430	Screw, 8 x .75	4				
	2325673	Decal, ctrl box 55 Autopilot & US2	1	540	2323404	Screw, 1/4-20	4	880	2328600	Flex finger	1				
220	2320200	Cover, ctrl box	1	545	2321915	Sideplate, left	1	885	2323710	Button, momentary, left	1				
225	2324030	Ctrl board, compass, Autpilot only	1	550	2263426	Screw, 1/4-20 x 1.25	2	900	2325660	Decal, foot pedal	1				
230	2302960	Grommet, compass, Autopilot only	3	555	2321925	Skid, left	1	910	2320205	Cover, heel-toe	1				
235	2065400	Wire insulator	2	560	2323422	Screw, 10-24 x .375	2	915	2323725	Button, AP	1				
240	2218200	Fuse Holder, US2 only	1	565	2321700	Washer, #10 SS	2	920	2323715	Button, Mom/Con	1				
245	2372100	Screw, 8-18 x .625	3	570	2327306	Bushing, pivot	2	925	2320100	Knob, speed, foot pedal	1				
250	2052510	Cable clamp	3	575	2323915	Ramp, 3 5/8" left	1	930	2332103	Screw, 6-20 x .375	2				
255	2322500	Ctrl box	1	580	2325115	Pad, rubber rest	4	935	2324020	Control board, foot pedal	1				
260	2332102	Screw, 10-24	1	585	2321706	Washer, #8	4	940	2322900	Strain relief, foot pedal	1				
265	2372100	Screw, 8-18 x .625	4	590	2323412	Screw, 8-18 x .25	4	945	2324500	Base plate, foot pedal	1				
270	2333101	Nut, 10-24	1	595	2324705	Insert, ramp	2	950	2301310	Screw, #8 x .5	10				
275	2224700	Plug, ctrl box, US2 motors only	1	600	2994202	Arm, release, left	1	955	2323700	Button, steer, left	1				
	2224702	Plug, ctrl box	1	605	2322710	Spring, extension	2	960	2323705	Button, momentary	1				
300	2211415	Universal sonar 2 extension cable	1	■	2770250	Cover, speed control with decal	1	965	2323701	Button, steer, right	1				
305	2771500	Depth collar Assembly	1	620	2325650	Decal, speed control	1	970	2322704	Spring, foot pedal	5				
315		Included in #305 assembly		625	2320210	Cover, speed control	1	975	2994859	Bumper, bag assy	1				
320		Included in #305 assembly		630	2322901	Strain relief	1	980	2322706	Spring, barrel	2				
325	2997050	Steering housing	1	635	2324011	Control board, 12v	1	985	2323420	Screw, 8-18 x .375	2				

* This item is part of an assembly. This item cannot be sold separately due to machining and /or assembly that is required.

P/N 2324930

REV. R 30800

4-08

2888460 Seal * Oring Kit

Terrova 55 is 12-volt only!

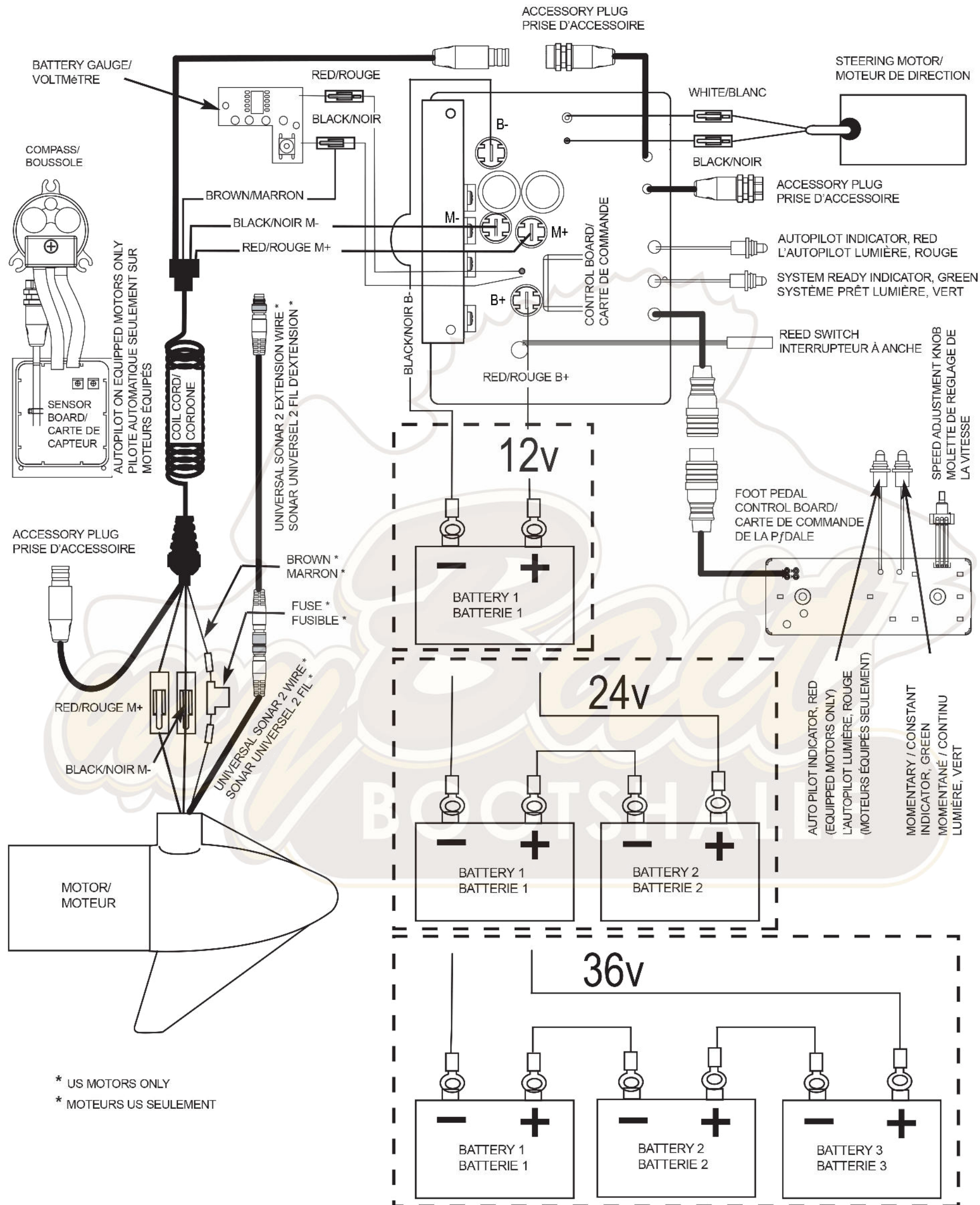

* US MOTORS ONLY
* MOTEURS US SEULEMENT