

RipTide 80/T
80 lbs Thrust
24 Volt 56 Amp
42" Shaft

for use with "AI" serial numbers
3-year warranty from the date of purchase

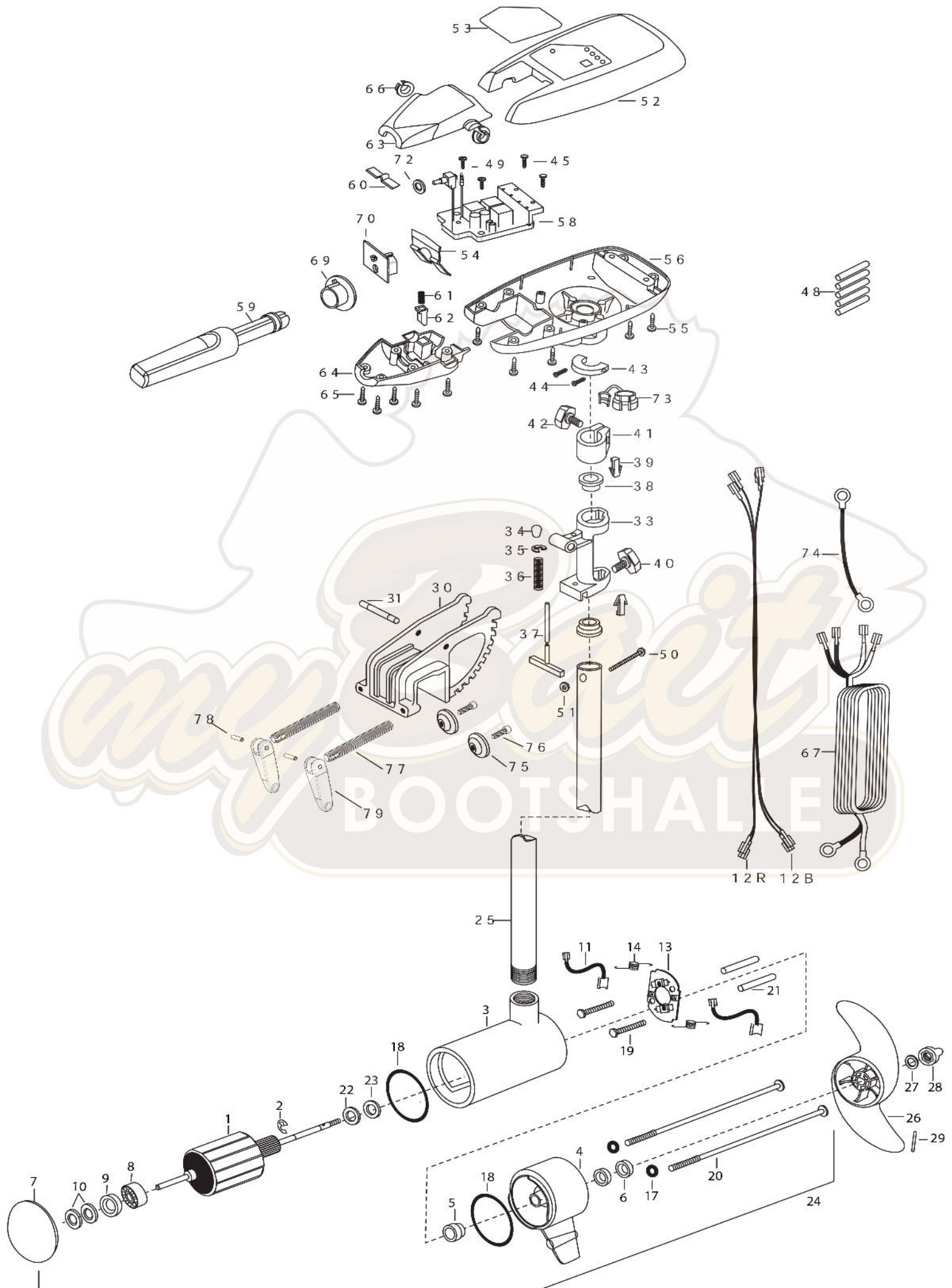

1	2-100-214	ARMATURE ASSEMBLY 36V VARS SW	29	2262658	PIN-DRIVE SS	60	2302742	SPRING-DETENT (OFF) SS
2	788-040	RETAINING RING	■	2991830	BRACKET & HINGE ASSEMBLY (SW)	61	2302745	SPRING-RELEASE BUTTON SS
3	2-200-397	CENTER HOUSING ASSEMBLY- 4.0 SW TXT WHT	30	2031934	BRACKET DIE CAST SW WHITE 10P	62	2303720	RELEASE BUTTON-HANDLE
4	2-300-340	BRUSH END HOUSING ASSEMBLY 4 SW WHT	31	2010512	PIN-DRIVE LOK 3/8X2-1/2 SS	63	2060411	HANDLE (TOP HALF) MAXIMIZE
5	144-017	BEARING -FLANGE (SERVICE ONLY)	33	2031856	HINGE-MACH SS RT WHITE	64	2060415	HANDLE (LOWER HALF)
6	880-025	SEAL [2.EA]	34	2010100	KNOB-TILT	65	2303412	SCREW-6-20 X 5/8 SELF TAP [5.EA]
7	421-376	PLAIN END HOUSING ASSEMBLY 4.0 WHT	35	2333001	E-RING- SS	66	2060005	BEARING-HANDLE PIVOT [2.EA]
8	140-010	BALL BEARING	36	2332700	SPRING- (T-BAR) SS	67	2050609	LEADWIRE (10 GA) SPADE TERM.
9	990-045	THRUST SPACER	37	2033601	T-BAR (E-COAT)	69	2992852	ACTUATOR-CAM
10	992-010	SPRING WASHER [2.EA]	38	2037301	BUSHING-HINGE [2.EA]	70	2184020	POT ADAPTER
11	188-094	BRUSH 4" W/TERMINAL [2.EA]	39	2062800	TENSION BLOCK- "SNAP IN" [2.EA]	72	2181700	WASHER, SPACER
12B	640-018	BRUSH WIRE BLACK 10 AWG 62"	40	2011386	SCREW-TENSION/NEW KNOB SS	73	2052900	STRAIN RELIEF-C.CORD/SP/C
12R	640-123	BRUSH WIRE RED 10 AWG 64"	41	2061520	COLLAR-DEPTH	74	2340610	CONNECTOR CABLE 12"
13	738-004	BRUSH PLATE -4" TERMINAL	42	2011366	SCREW-COLLAR/NW KNOB SS	75	2331700	WASHER, CLAMP SCREW SS [2.EA]
14	975-041	SPRING -TORSION [2.EA]	43	2061517	COLLAR-CTRL BOX SW WHITE	76	2263452	SCREW 1/4-20 X 3/4 SS [2.EA]
17	701-009	O-RING -THRU BOLT [2.EA]	44	2263434	SCREW #8-3/4 PPH TYPE 25 SS [2.EA]	77	2051301	CLAMP SCREW [2.EA]
18	701-043	O-RING [2.EA]	45	2043427	SCREW-8-18 X 7/8 SS [2.EA]	78	2052625	PIN-HANDLE
19	830-027	SCREW -SELF THREADED 10-32 X 2"[2.EA]	48	2305400	SHRINK TUBE-3/8 OD X 1-1/ [5.EA]	79	2050925	HANDLE-SCREW
20	830-096	THRU BOLT 12-24 X 11.56" SS [2.EA]	49	2043427	SCREW-8-18 X 7/8 SS [2.EA]	■	2991301	CLAMP SCREW-HANDLE ASSEMBLY (INCLUDES ITEMS 77,78,79)
21	973-025	SPACER -BRUSH PLATE [2.EA]	50	2263406	SCREW-#10-24 X 2 (SS) PPH			
22	990-051	WASHER-STEEL THRUST	51	2333101	NUT-HEX 10-24 UNC-2B NYLOCK			
23	990-052	WASHER- NYLATRON	52	2300219	COVER- CONTROL BOX (SW) RT WHITE			
24	2316228	MOTOR ASSEMBLY 36V VARS WHITE	53	2095684	DECAL-COVER RT80/B/S			
25	2032032	TUBE (COMPOSITE) 42" WHITE	54	2302743	SPRING-DETENT HANDLE-TILT			
■	1378132	PROPELLER KIT	55	2303412	SCREW-6-20 X 5/8 SELF TAP [6.EA]			
26	2331160	PROPELLER (WW2)	56	2062596	CONTROL BOX,SW, WHITE .725 BORE			
27	2091701	WASHER- PROP LARGE MAX	58	2184005	CTRL BOARD ASSEMBLY-RT 80			
28	2198401	ANODE- ZINC 4.0 LWR UNIT	59	2990915	HANDLE ASSEMBLY W/O U-JOINT			

RipTide 80T is 24-volts only!

wiring diagram for control board #2184003:

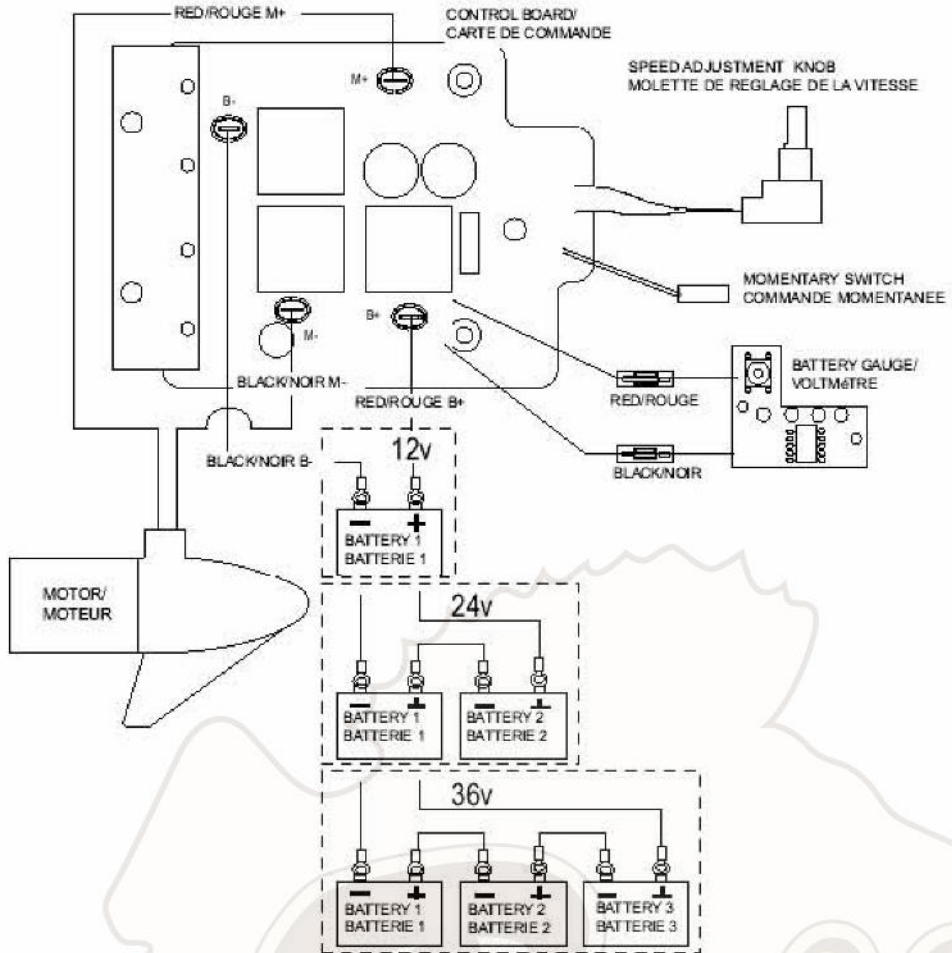

wiring diagram for control board #2184005:

