

45PD
45 LBS THRUST
12 VOLT 42 AMPS
48" SHAFT

for use with "L" serial numbers
2-year warranty

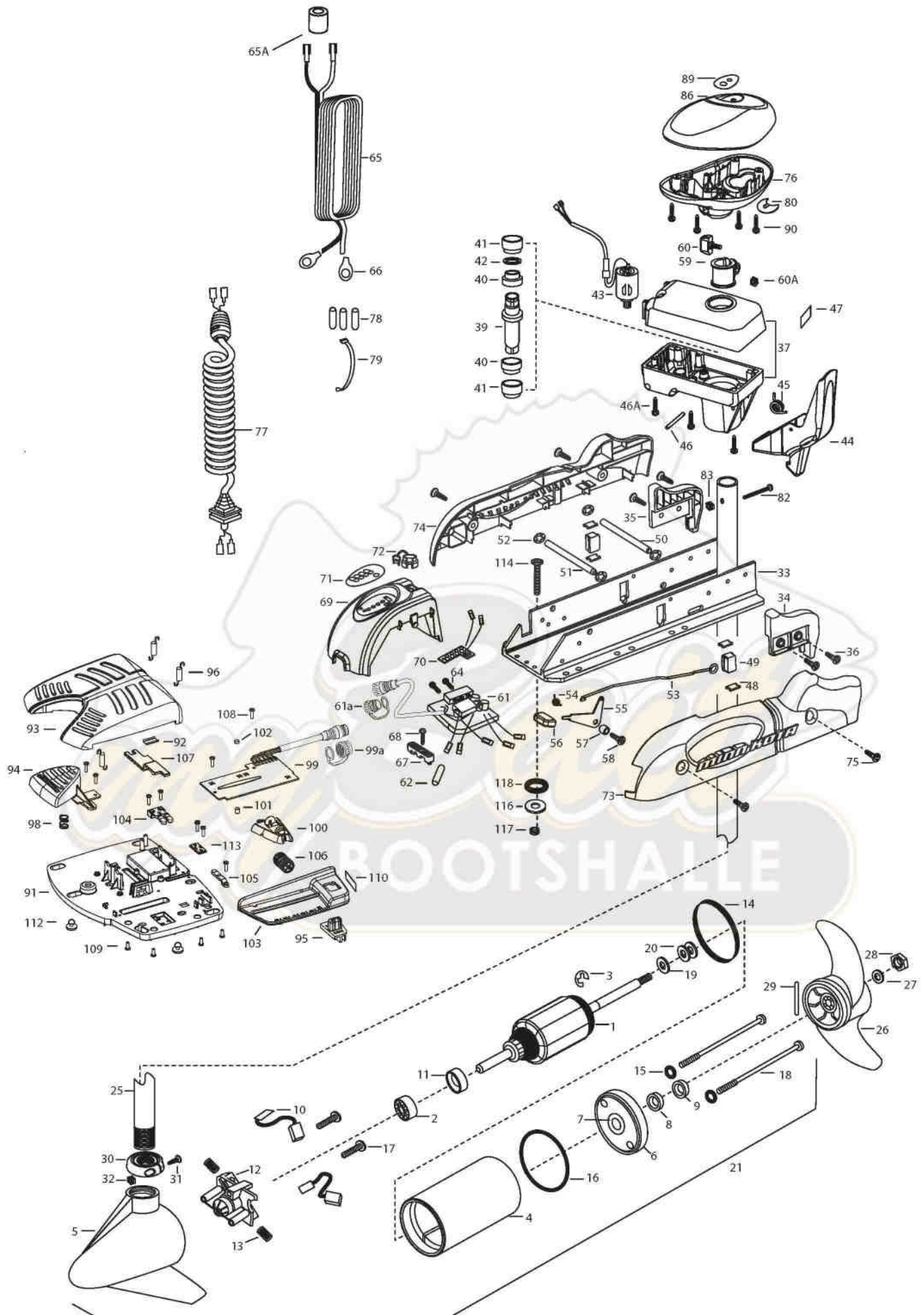

In the U.S.A., replacement parts may be ordered directly from MINN KOTA Parts Dept., 121 Power Drive,P.O. Box 8129 Mankato, Minnesota 56002-8129. In Canada, parts may be ordered from any of the Canadian Authorized Service Centers shown on the enclosed list. Be sure to provide the MODEL and SERIAL numbers of your motor when ordering parts. Please use the correct part numbers from the parts list. Payment for any parts ordered from the MINN KOTA parts department, may be by cash, personal check, Discover Card, MasterCard or VISA. To order, call 1-800-227-6433 or FAX 1-800-527-4464.

Hors de États-Unis, voir la liste ci-jointe pour le Centre de Service Agréé MINN KOTA le plus proche. Lors d'une commande, ne pas oublier de fournir le numéro de modèle et le numéro de série du moteur. Toujours mentionner le numéro de pièce exact figurant sur la liste des pièces de rechange.

1	2-100-202	ARMATURE ASSEMBLY 12V VARS TXT	43	2307050	MOTOR- DRIVE HOUSING HIGH SPD	80	2224702	INSERT- PLUG
2	140-010	BALL BEARING	44	2307201	LATCH HANDLE PD/AP		2224700	INSERT- PLUG US2
3	788-015	RETAINING RING	45	2302750	SPRING- LATCH TORSION PD/AP			
4	2-200-079	HOUSING ASSEMBLY CENTER 3.25 TXT	46	2302627	PIN- ROLL ZINC	82	2033400	SCREW-10-24 X 1-3/4 PPH Z/P
5	421-132	HOUSING BRUSH END 3.25 TXT	46A	2303407	SCREW - DRIVE HOUSING [6 EA]	83	2013110	NUT-HEX 10-24 ZCP
6	2-400-187	PLAIN END HOUSING ASSEMBLY 3.25	47	2305564	DECAL-STOW/DEPLOY	86	2300237	CONTROL BOX COVER- POWERDRIVE
7	144-049	BEARING - FLANGE (SERVICE ONLY)	48	2305110	PAD-PIVOT SUPT [4.EA]	89	2315692	DECAL- COVER 45PD
8	880-003	SEAL	49	2305103	PIVOT PAD- NEW MTR'L [2.EA]	90	2012100	SCREW-8-18 X 5/8 THD CUT [4.EA]
9	880-006	SEAL WITH SHIELD	50	2300500	PIN-LATCH	■	2994725	FOOT PEDAL ASSEMBLY
10	188-052	BRUSH ASSEMBLY [2.EA]	51	2300510	PIN-PIVOT	91	2304505	FOOT PEDAL BASE
12	738-030	BRUSH PLATE W/HOLDER	52	2013100	NUT-SPEED [4.EA]	92	2308501	WEAR PLATE FOOT PDL
13	975-032	SPRING - COMPRESSION [2.EA]	53	2303612	ROD-RELEASE RT/AP S	93	2300255	FOOT PEDAL, CORDED UPPER
14	701-041	O-RING	54	2322700	SPRING-RELEASE LEVER	94	2303723	BUTTON, MOMENTARY
15	701-007	O-RING, THRU-BOLT [2.EA]	55	2303710	LEVER-RELEASE	95	2303722	BUTTON, MOM/CON
16	701-039	O-RING	56	2300101	RELEASE-KNOB	96	2302730	SPRING-LONG-UPPER PEDAL [3.EA]
17	830-001	SCREW-8-32 [2.EA]	57	2301700	SPACER-RELEASE LEVER	98	2302732	SPRING-LOWER PEDAL
18	830-078	THRU BOLT 8-32 X 8.96 [2. EA	58	2303430	SCREW-1/4-20 X 5/8	99	2304052	CONTROL BOARD ASSEMBLY-FT PDL
19	990-067	WASHER- STEEL THRUST	59	2031522	COLLAR- DRIVE (W/INSERT)	99A	2320207	DUST CAP
20	990-070	WASHER - NYLATRON [2.EA]	60	2011365	SCREW-COLLAR/NEW KNOB	100	2308620	SLIDER, SPEED
21	2069253	MOTOR ASSEMBLY 12V 3.25 48"	60A	2323104	NUT	101	2308409	MAGNET, 1/4 X 1/4
25	2032075	TUBE-CARBON COMPOSITE 48"	61	2304060	CONTROL BOARD ASSEMBLY- 12V PD	102	2778408	MAGNET, 1/4 X 1/8
■	1378121	PROPELLER KIT	61A	2320208	DUST PLUG	103	2300252	COVER, SPEED SELECTOR
26	2061122	PROPELLER	62	2355410	SHRINK TUBE-3/8 ODX2	104	2308606	SWITCH, DOUBLE FINGER
27	2151726	WASHER-5/16 SS	64	2303434	SCREW-8-32 X 5/8 [3.EA]	105	2308608	SWITCH, SINGLE FINGER
28	2053101	NUT-PROP NYLOC	65	2090651	LEADWIRE IOGA 44"	106	2307900	WHEEL, SPEED
29	2092600	PIN-DRIVE	65A	2307310	BEAD - FERRITE (CE MODELS ONLY)	107	2308625	SLIDER, STEERING
30	2301545	COLLAR- LATCH PD/AP	66	2020700	TERMINAL RING [2.EA]	108	2302100	SCREW-6-20 X 1/2 [9.EA]
31	2303434	SCREW- 8-32X5/8 MACH PHCR	67	2321310	STRAIN RELIEF- BRACKET PD/AP	109	2372103	SCREW-6.20 X 3/8 [4.EA]
32	2303112	NUT 8-32 NYLOC SS	68	2323405	SCREW-1/4-20 X 5/8	110	2316600	DECAL, ON/OFF SWITCH
33	2301936	EXTRUSION- BASE MACHINED	69	2306555	HOUSING- CENTER PD/AP	112	2994859	BAG ASSEMBLY- 4 RUBBER BUMPERS
34	2303930	MOTOR REST- RIGHT 3-1/4	70	2074070	BATTERY GAUGE - 12 VOLT	113	2302907	STRN RLF PD FP
35	2303935	MOTOR REST- LEFT 3-1/4	71	2316605	DECAL, BATTERY GAUGE	■	2994864	BAG ASSEMBLY- (BOLT,NUT,WASHERS)
36	2303430	SCREW 1/4-20X5/8 SELF TAP [4.EA]	72	2302935	STRAIN RELIEF-DR. HOUSING	*114	2263462	BOLT-MOUNTING-1/4X2 W/STG [6.EA]
37	2771826	DRIVE HOUSING / LATCH HANDLE ASSY	73	2303960	SIDEPLATE (RIGHT)PD MK	*116	2261713	WASHER-1/4 [6.EA]
■	2882011	BUSHING/ OUTSHAFT KIT (INCLUDES 39-42)	74	2303965	SIDEPLATE(LEFT)PD MK	*117	2263103	NUT NYLOK 1/4-20 MTG [6.EA]
*39	2302010	DRIVE HOUSING OUTPUT SHAFT	75	2303430	SCREW-1/4-20 X 5/8- [4.EA]	*118	2301720	WASHER-MOUNTING RUBBER [6.EA]
*40	2307304	BUSHING- INNER [2.EA]	76	2302515	CONTROL BOX PD/AP			
*41	2307305	BUSHING- OUTER [2.EA]	77	2991280	COIL CORD WSTRAIN RELIEF 48, 54"	■	2883460	SEAL & ORING KIT
*42	2304603	O-RING		2991282	COIL CORD WSTRAIN RELIEF 60"			
			78	2065400	WIRE INSULATOR-LGE 1-3/4 [3.EA]			
			79	2256300	TIE WRAP-5" BLACK			

* This item is part of an assembly. This item cannot be sold separately due to machining and /or assembly that is required.

P/N 2314966

REV. B

ECN 31445 5-09

12-24 VOLT MODELS / MODÈLES 12-24 V

THIS IS A UNIVERSAL MULTI-VOLTAGE DIAGRAM. DOUBLE CHECK YOUR MOTORS VOLTAGE FOR PROPER CONNECTIONS
CECI EST UN SCHÉMA À TENSION MULTIPLE UNIVERSEL. RÉVÉRIFIEZ LA TENSION DE VOTRE MOTEUR POUR BIEN LE BRANCHER.

PowerDrive 45 is 12-volt only!

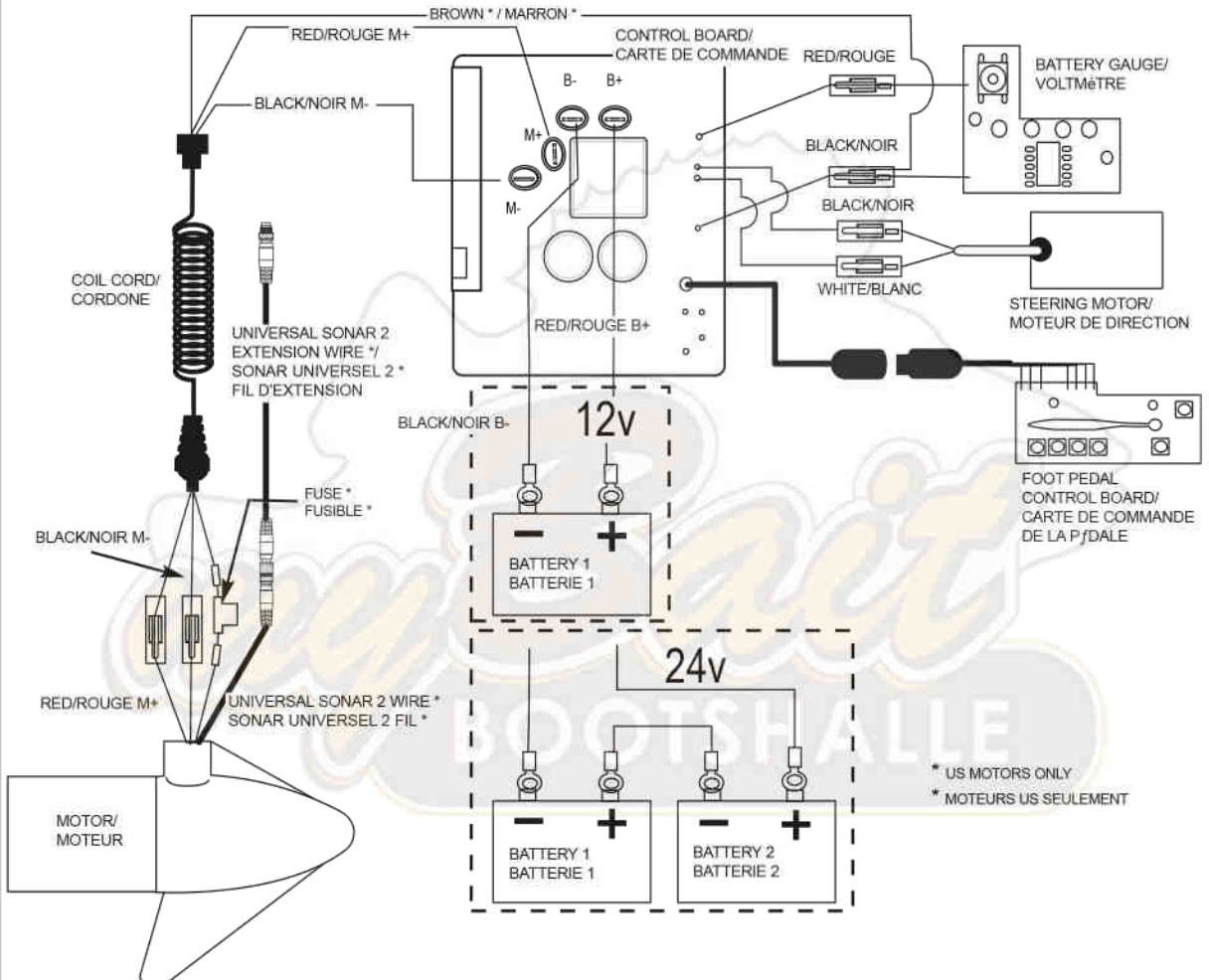

NOTE:

1. BATTERY 2 AND CONNECTING WIRE USED FOR 24V APPLICATIONS ONLY
2. UNIVERSAL SONAR 2 WIRES APPLICABLE TO US2 MOTORS ONLY

NOTEZ :

1. LA BATTERIE 2 DE CONNEXION LE FIL UTILISÉ POUR 24V LES APPLICATIONS SEULEMENT
2. LE SONAR UNIVERSEL 2 FILS APPLICABLES AUX MOTEURS US2 SEULEMENT